

HALLE

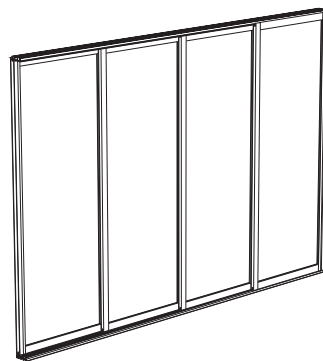
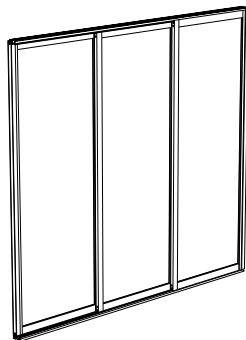
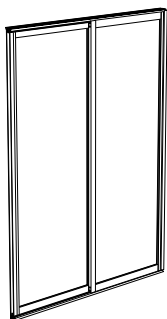
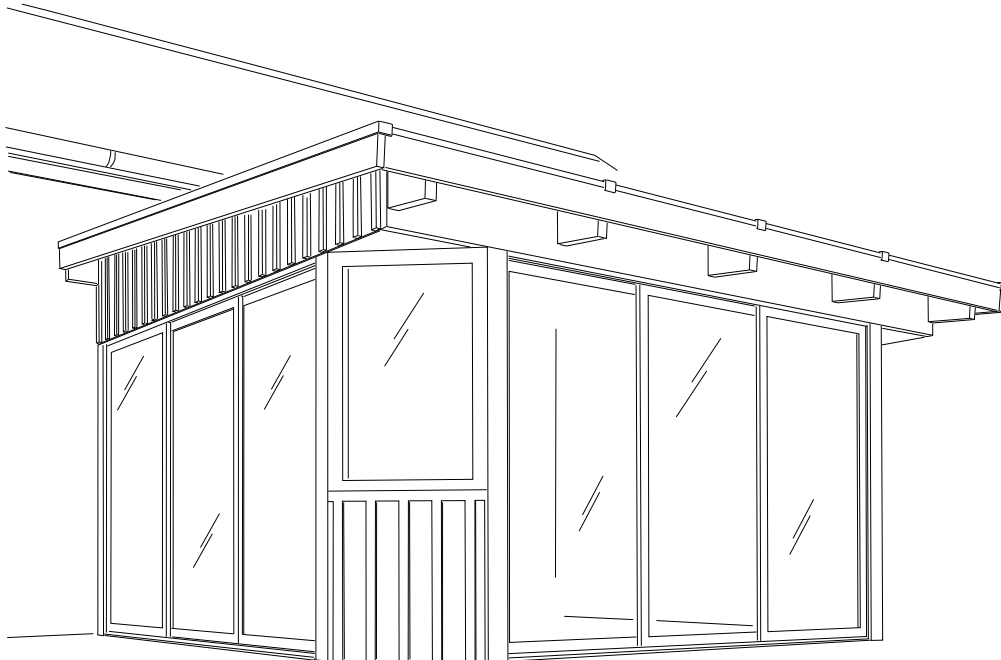

Primolux

Primolux Isoler

2d - 3d - 4d

Skjutbara partier - Skydedøre - Skyvedører - Sliding doors - Liukuovet

Primolux Primolux isoler

2d - 3d - 4d

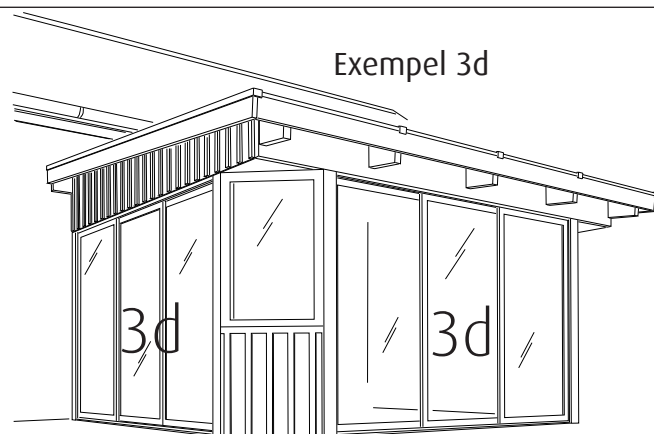

Skjutbara partier - Skydedøre - Skyvedører - Sliding doors - Liukuovet

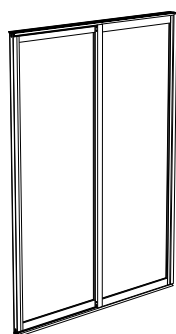

2d

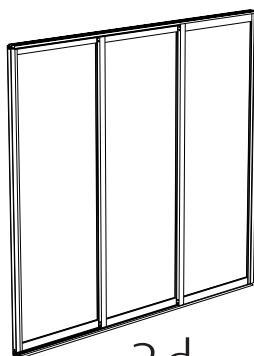

3d

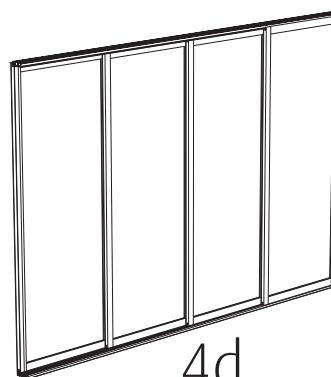

4d

1990mm

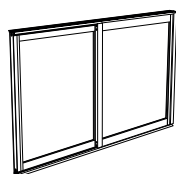

2d

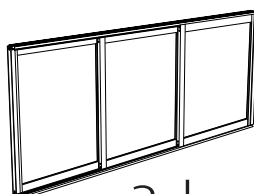

3d

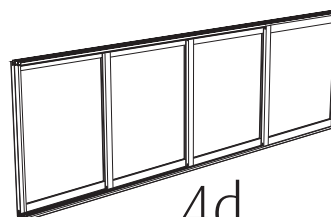

4d

1190mm

Räls övre/undre - øvre/nedre - Skinner øvre/nedre - Tracks upper/lower - Ylä-/alakiskot

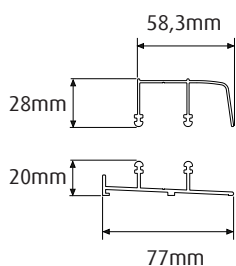

2d = 2-spår skena

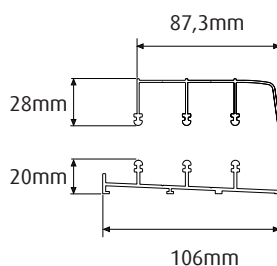

3d = 3-spår skena

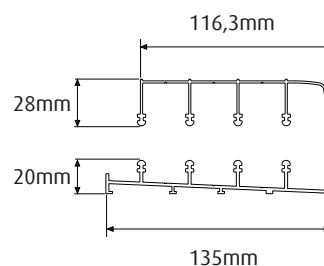

4d = 4-spår skena

Skenor övre och undre levereras i övermått - Skinner over og under leveres i over længde - Skinner øvre og nedre leveres i overlængde
Rails upper and lower are delivered in over length - Ylä- ja alakiskotteet toimitetaan yli pitkinä

Alternativ Rättvänt/Speglvänt - Right-handed/Left-handed. Seen from the outside of the building

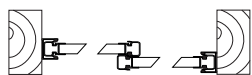

Rättvänt - Right-handed

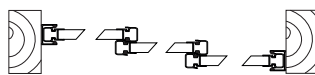

Rättvänt - Right-handed

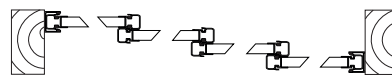

Rättvänt - Right-handed

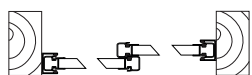

Speglvänt - Left-handed

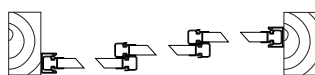

Speglvänt - Left-handed

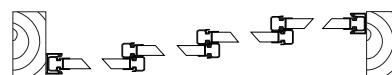

Speglvänt - Left-handed

- SE** Läs igenom anvisningen innan du börjar montera.
- DK** Læs instruktionerne, inden montering.
- NO** Les instruksjonene før du begynner å montere.
- GB** Read the instructions before you start assembly.
- FI** Lue ohjeet ennen kokoamista.

HALLE

Kontrollera leverans. Antal kolli och delar. Kontrollera så det inte blivit transportskador. Monterad artikel ersätts ej i efterhand.

Tjek levering. Antal pakker og dele. Tjek for transportskader. Monteret artikel udskiftes ikke bagefter.

Sjekk levering. Antall pakker og deler. Sjekk for transportskader. Monterte artikkel erstattes ikke etterpå.

Check the delivery. Check the number of packages and parts. Check for transport damage. Parts cannot be replaced after being assembled.

Tarkista toimituksen pakkausten ja osien lukumäärä. Tarkista mahdolliset kuljetusvauriot. Asennettua tuotetta ei voi vaihtaa jälkikäteen..

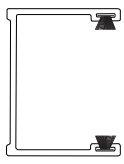

B x2

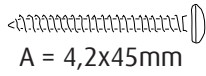

A = 4,2x45mm



AA



C

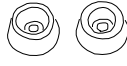

D

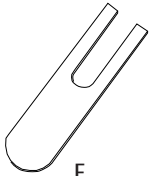

E

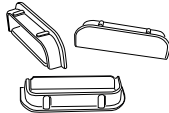

F

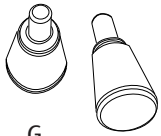

G

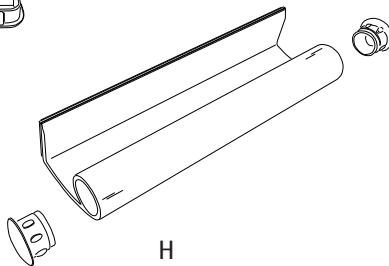

H

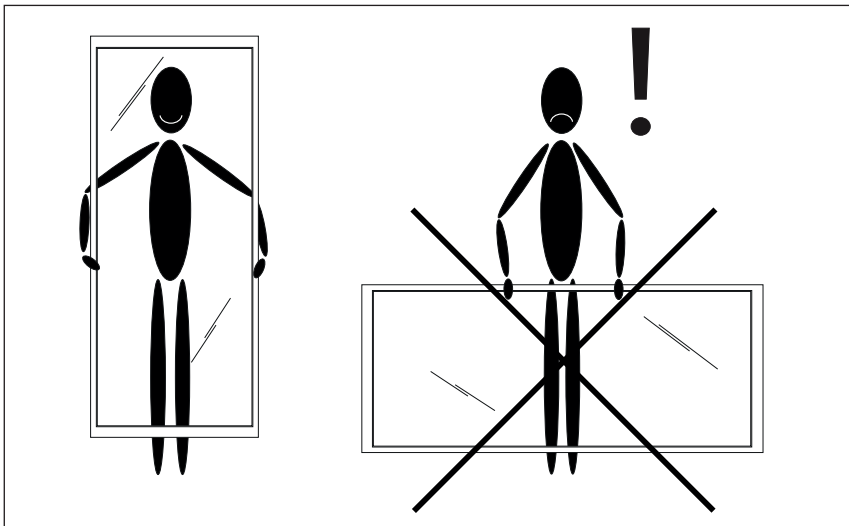

SE Vid transport kan skevhet uppstå. Krydsmät diagonalmättet. Vid justering. Placera en träkloss mot dörren och knacka försiktigt med en gummiklubba.

DK Under transport kan der opstå skævhed. Krydsmål den diagonale måling. Ved justering. Anbring en træklods mod døren, og bank forsigtigt med en gummihammer.

NO Under transport kan det oppstå skjevhet. Tverrmål den diagonale målingen. Ved justering. Plasser en trekloss mot døren og bank forsiktig med en gummiklubbe.

GB During transport, skew can occur. Cross measure the diagonal measurement. To adjust, place a wooden block against the door and tap gently with a rubber mallet.

FI Tuote voi taipua kuljetuksen aikana. Mittaa pituus kulmasta kulmaan. Suorista tuote asettamalla puukappale ovea vasten ja napauttamalla sitä kevyesti kumivasaralla.

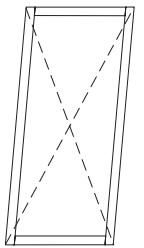

Verktøy som kan behövas / Værktøj, der kan være nødvendigt / Verktøy som kan være nødvendig / Tools that may be needed / Tarvittavat työkalut.

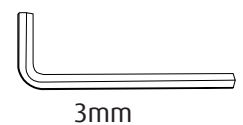
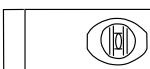
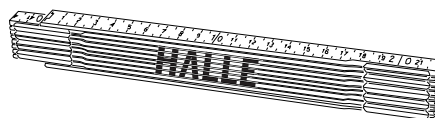
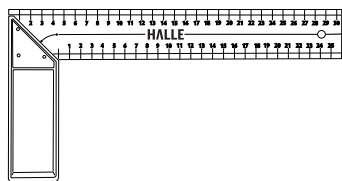
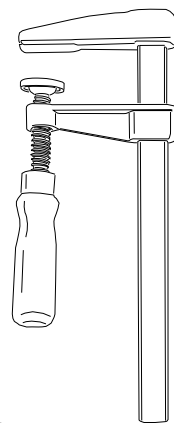
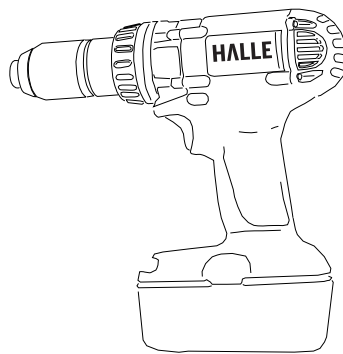
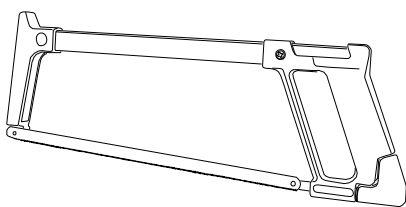

3mm



3,5mm 4,5mm 7mm 9mm

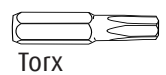

Torx

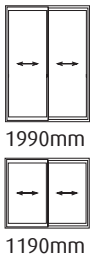
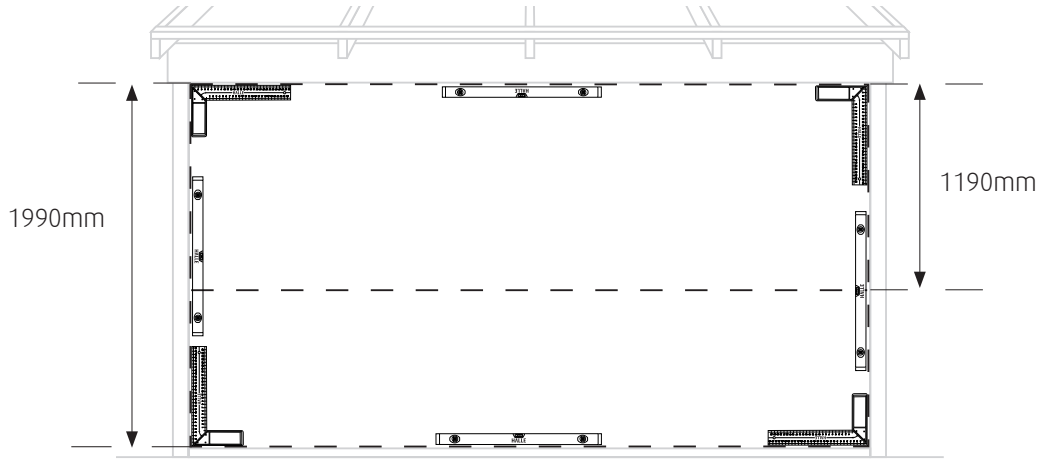
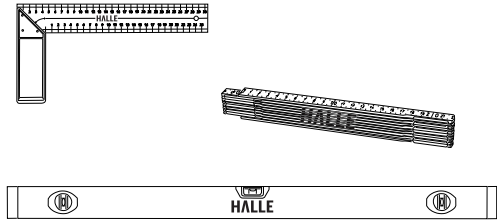
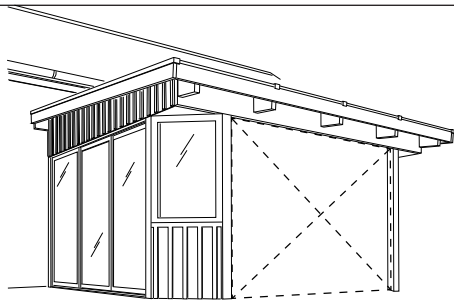

Ö-mått	Enheter per bredd			
	760	860	960	1060
1495	2			
1595	1	1		
1695		2		
1795		1	1	
1895			2	
1995			1	1
2095				2

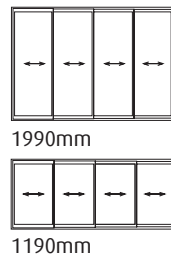

Ö-mått	Enheter per bredd			
	760	860	960	1060
2925	4			
3025	3	1		
3125	2	2		
3225	1	3		
3325		4		
3425		3	1	
3525		2	2	
3625		1	3	
3725			4	
3825			3	1
3925			2	2
4025			1	3
4125				4

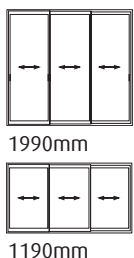
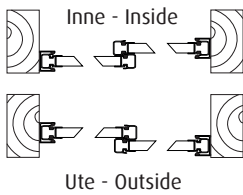

Ö-mått	Enheter per bredd			
	760	860	960	1060
2210	3			
2310	2	1		
2410	1	2		
2510		3		
2610		2	1	
2710		1	2	
2810			3	
2910			2	1
3010			1	2
3110				3

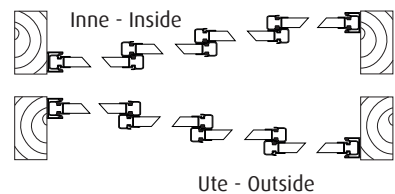

Dörrhöjd - Dørhøjde - Dørhøyde - Door height - Oven korkeus: 1990mm.

Fönsterhöjd - Vindueshøjde - Vinduhøyde - Window height - Ikkunan korkeus: 1190mm.

Ö-mått =

Öppningsmått mellan pelarnas insidor.

Åbningsmål mellem inder siden af søjlerne.

Åpningsmål mellom innsiden av kolonnene.

Opening dimensions between the insides of the columns.

Pylväiden sisäosien välisten aukkojen mitat.

Enheter per bredd =

Enheder pr. bredde.

Enheter per bredde.

Units per width.

Yksikköä leveyttä kohti.

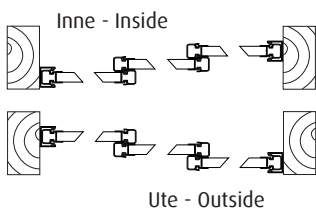

1

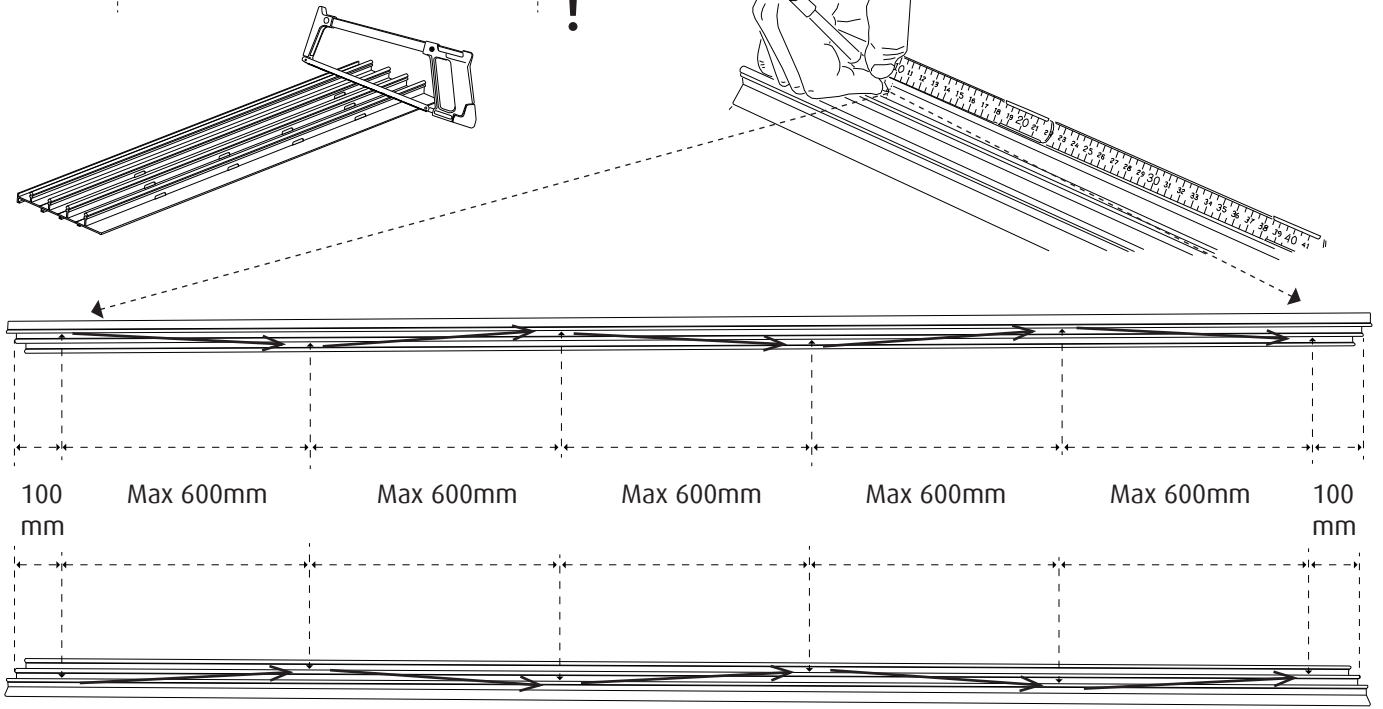
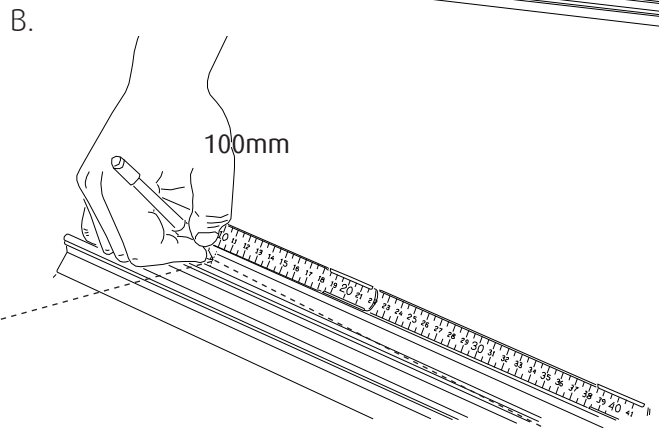
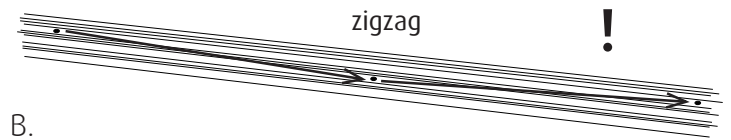
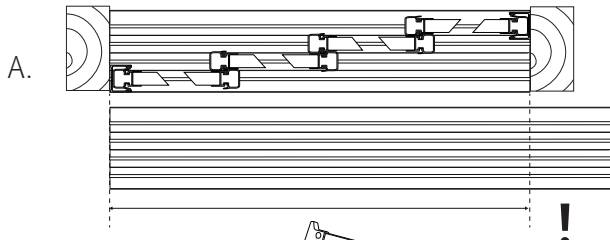

2

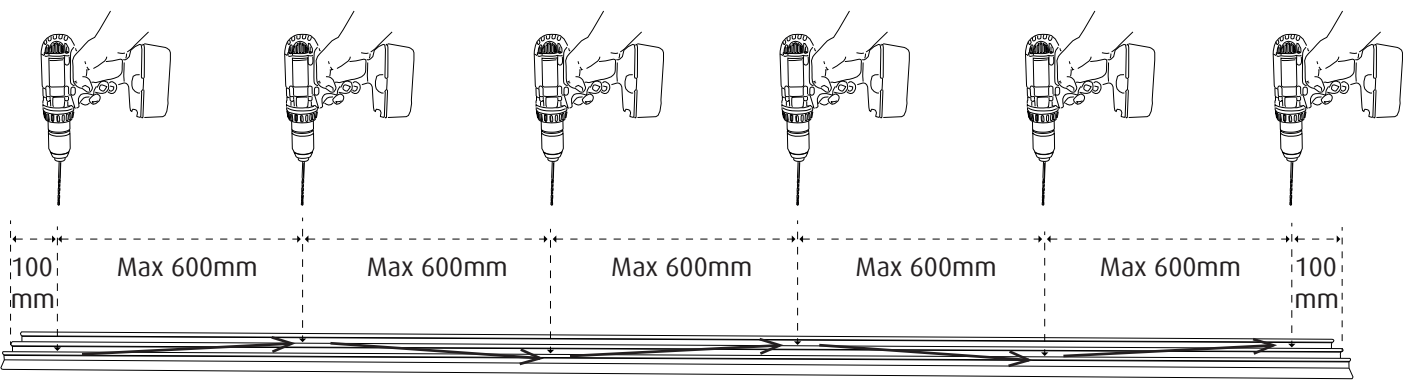
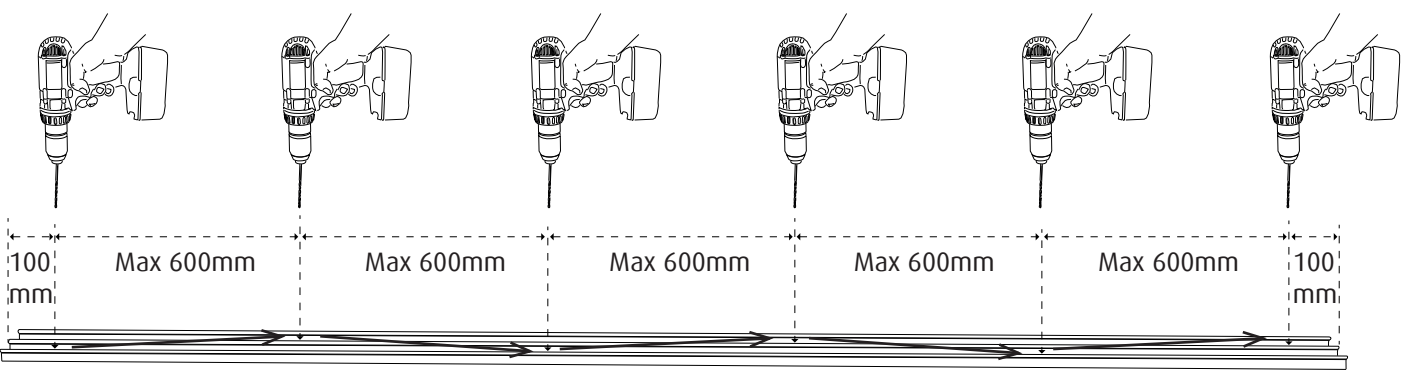
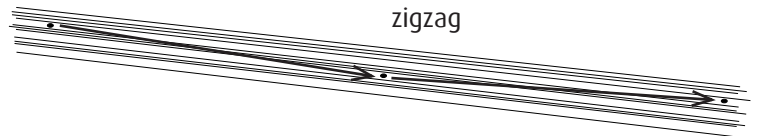

3 Undre skena - Nedre skinne - Nedre skinne - Lower rail - Alakisko

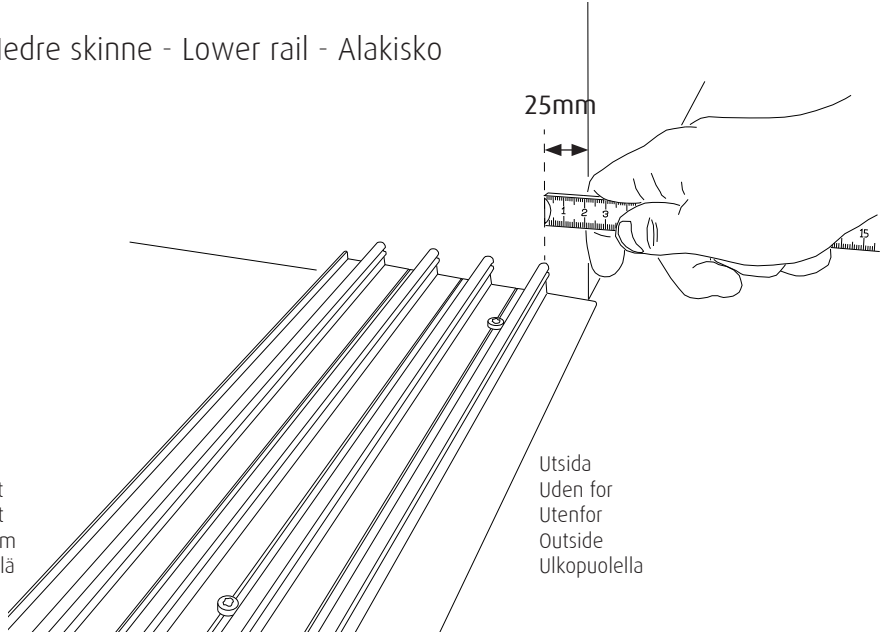
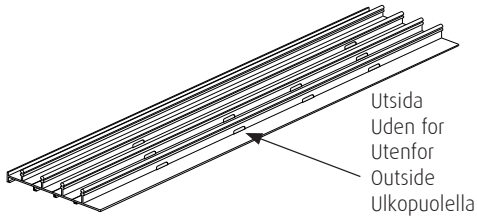

Innsida rum
Inde i rummet
Inne i rummet
Inside the room
Huoneen sisällä

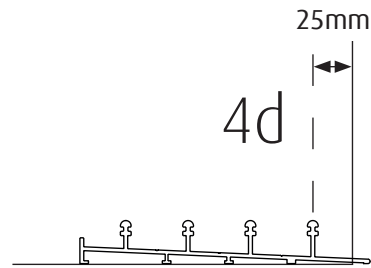
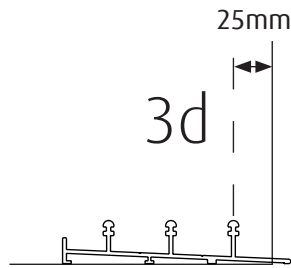
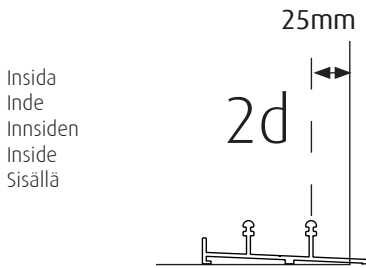

4 Övre skena - Øvre skinne - Øvre skinne - Upper track - Yläkisko

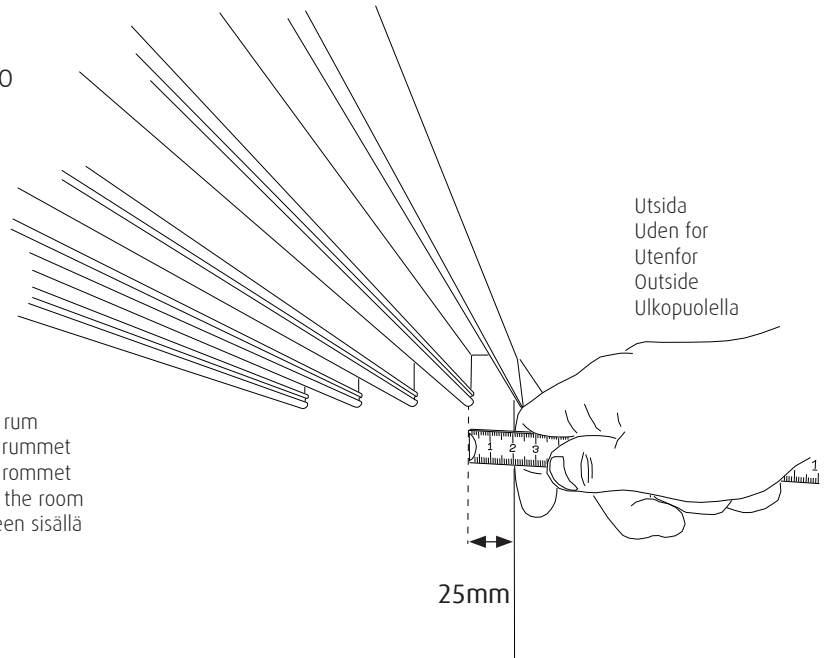

Innsida rum
Inde i rummet
Inne i rummet
Inside the room
Huoneen sisällä

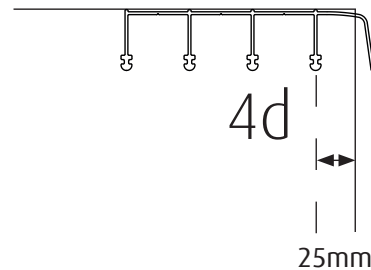
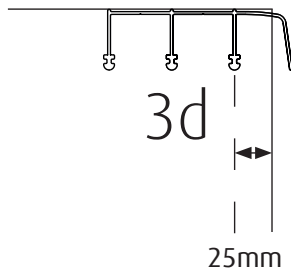
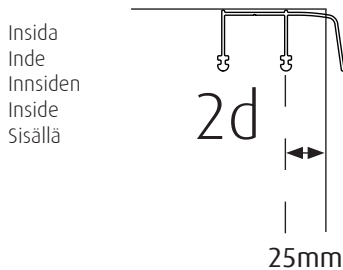

Utsida
Uden for
Utenfor
Outside
Ulkopuolella

5

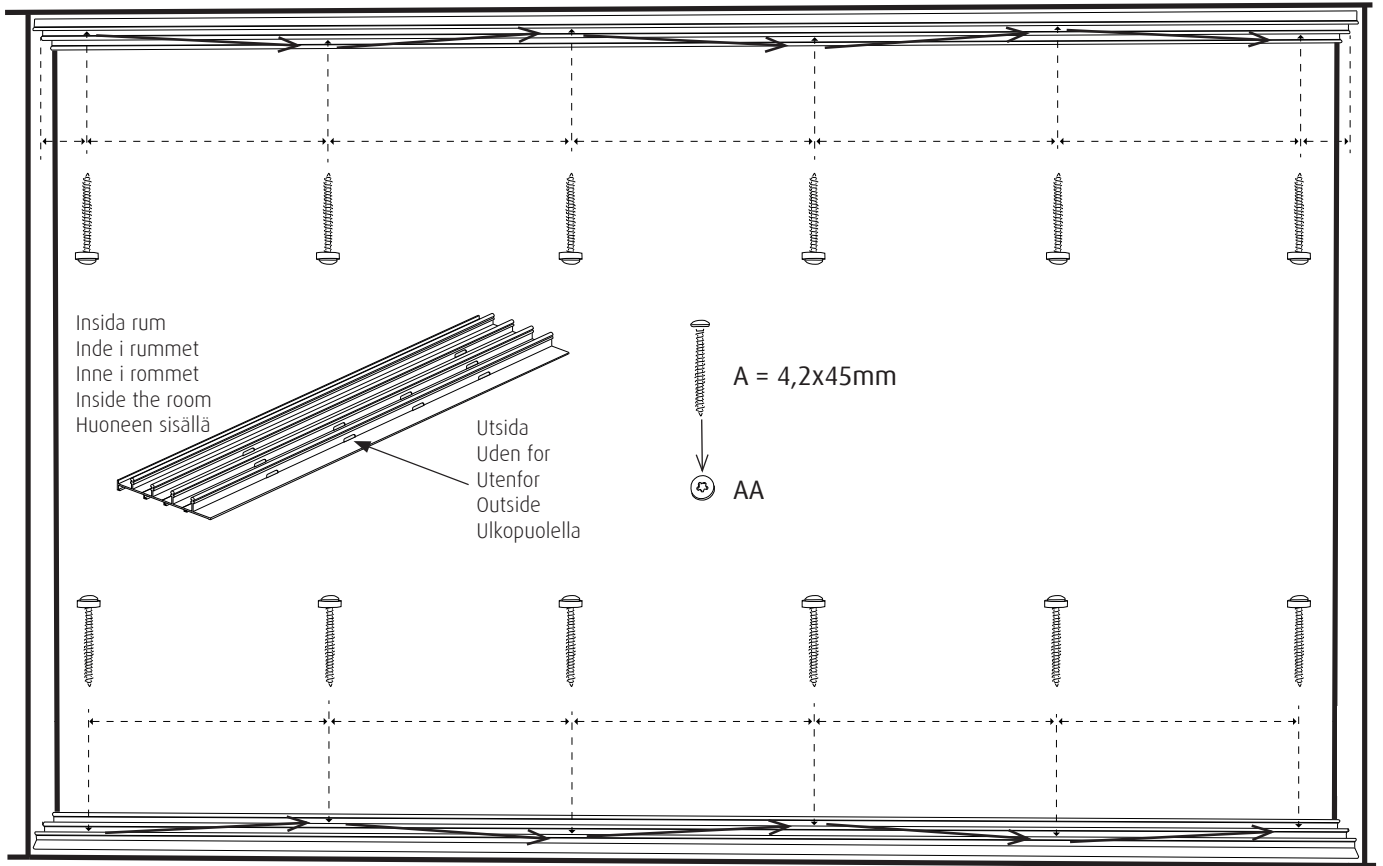

6

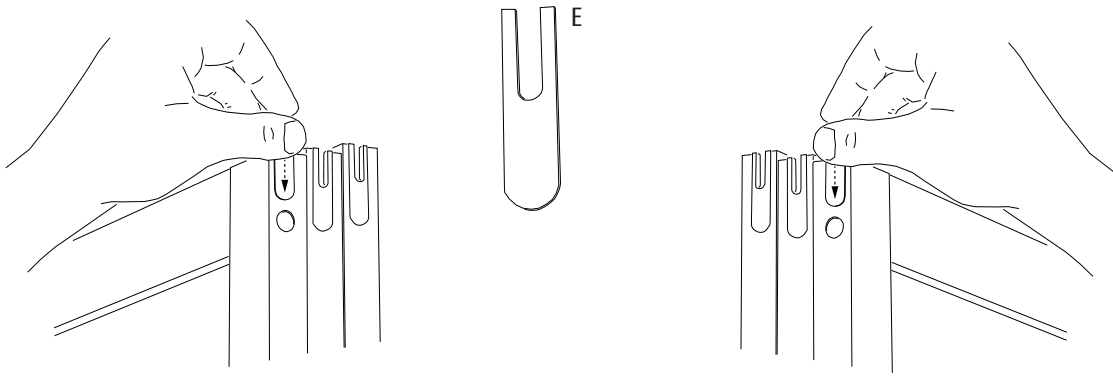

7

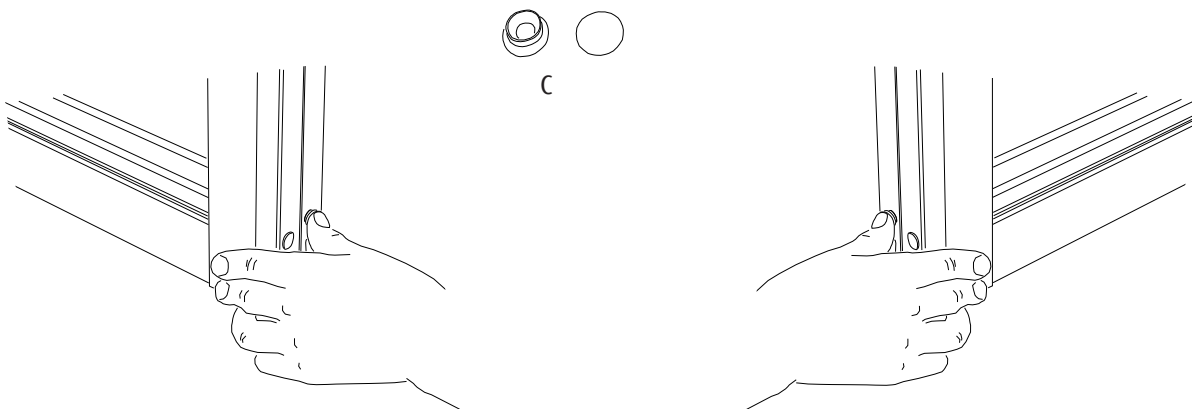

8

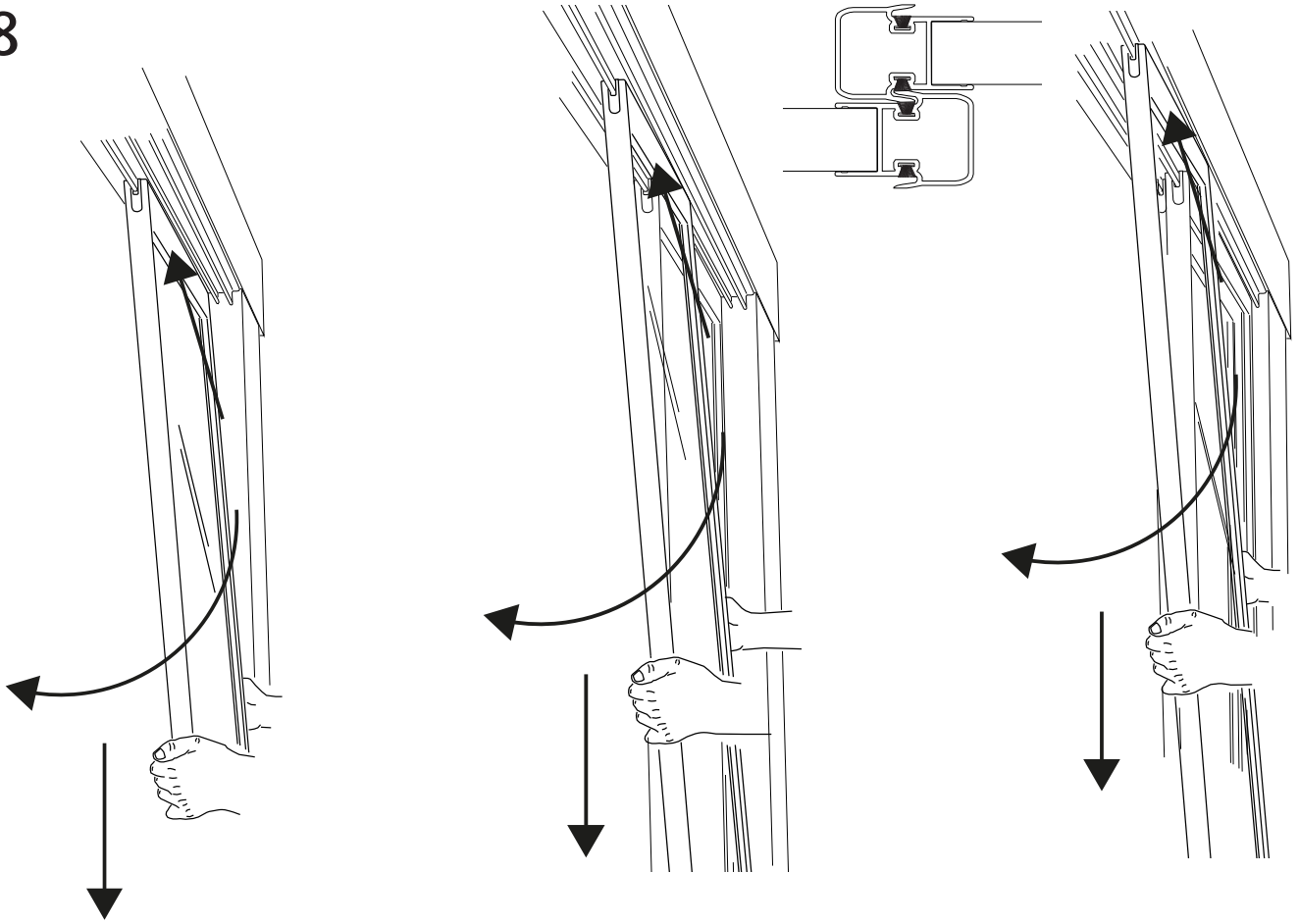

9

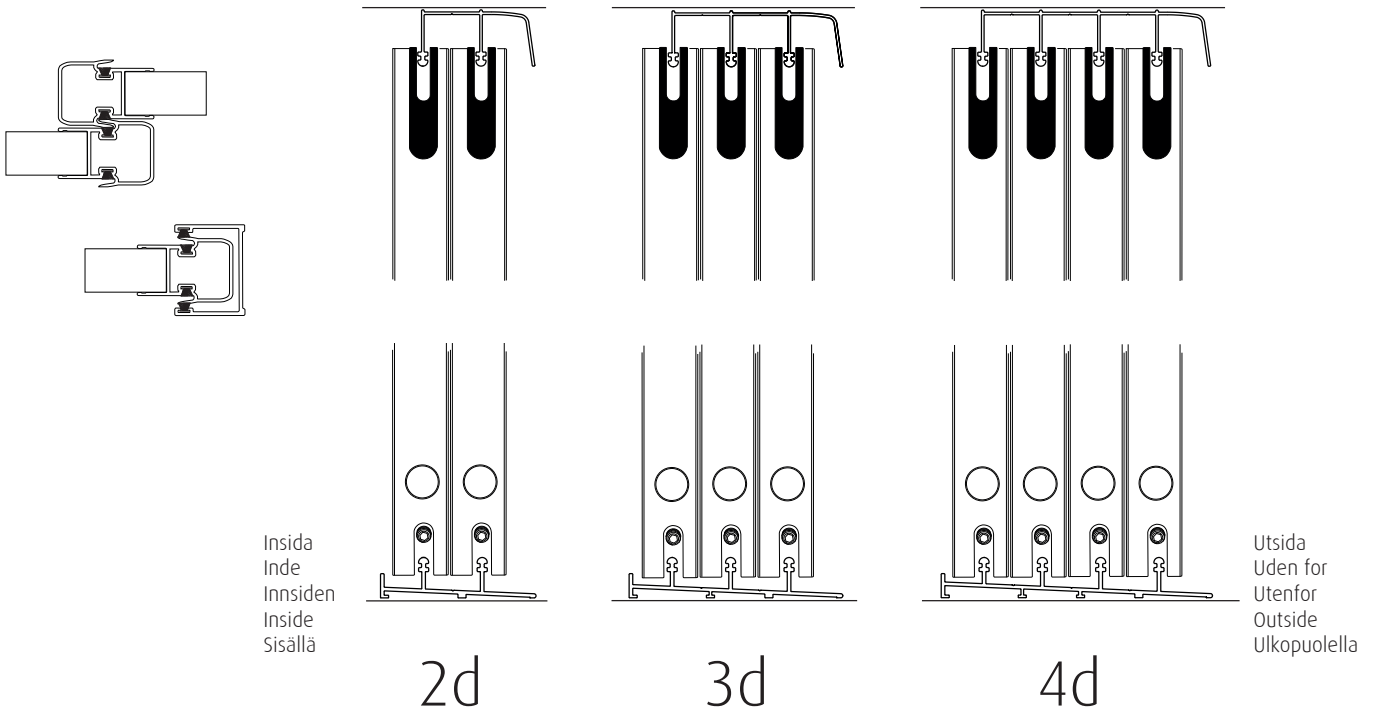

10

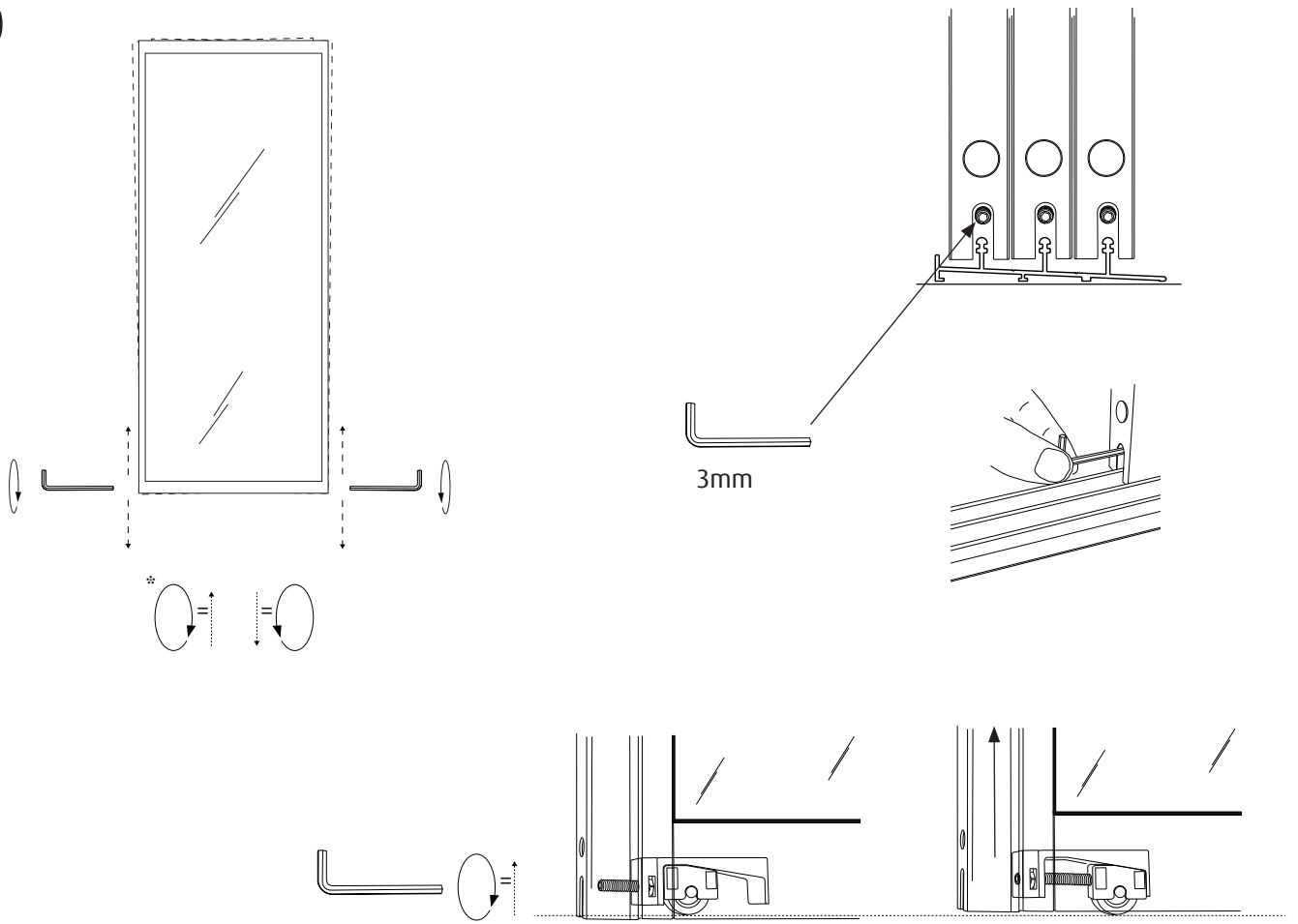

11

Insida rum
Inde i rummet
Inne i rommet
Inside the room
Huoneen sisällä

Utsida
Uden for
Utenfor
Outside
Ulkopuolella

Båda sidor!
Begge sider!
Both sides!
Molemmin puolin!

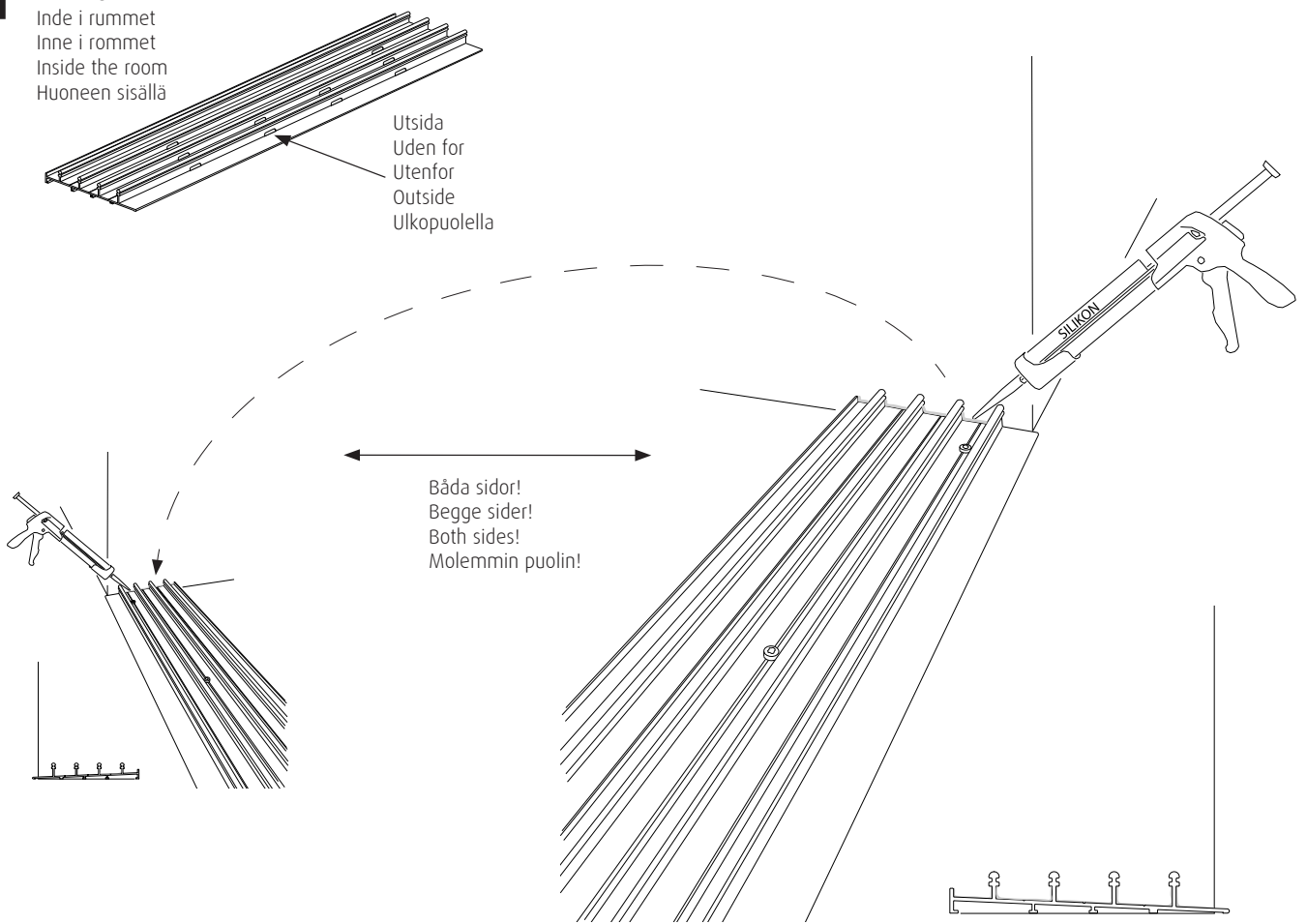

12

B

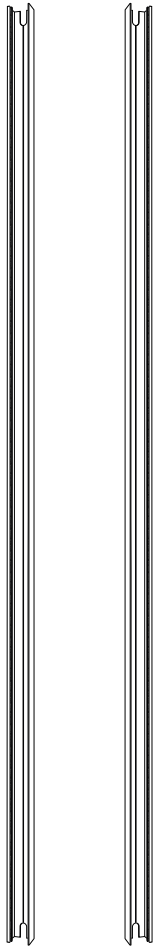

x2

13

Dörrhöjd/Dørhøyde/Door height

≈100-150mm

≈100-150mm



centrum

≈100-150mm

≈100-150mm

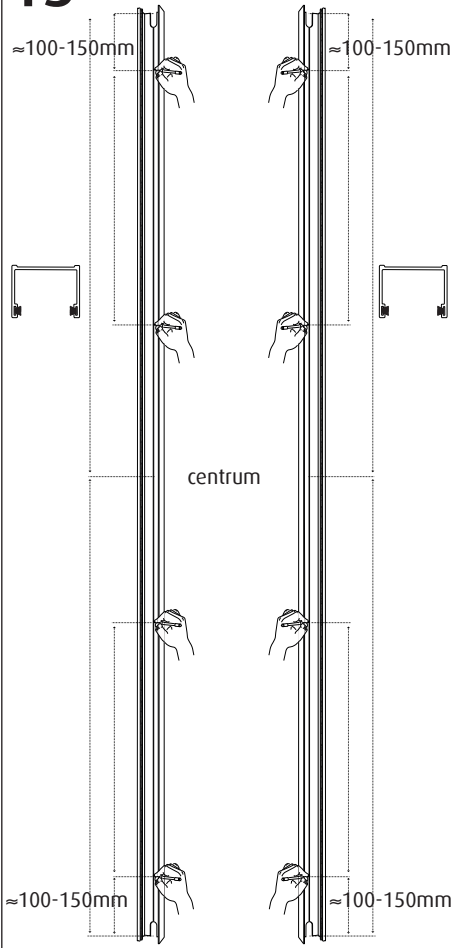

14

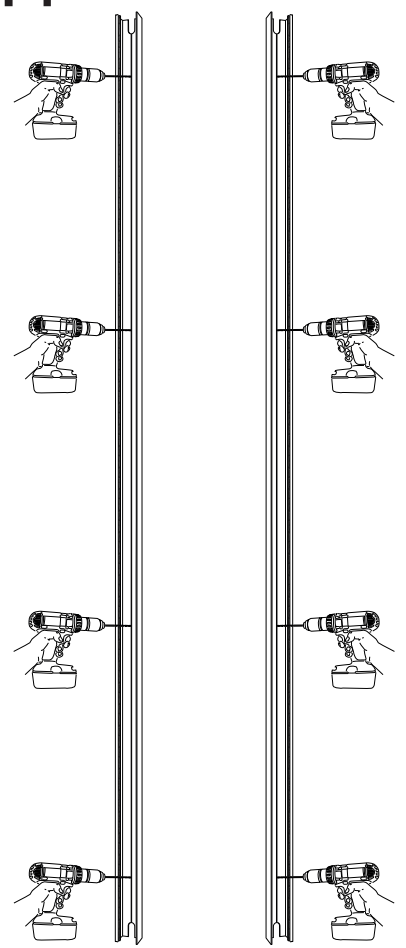

15

B

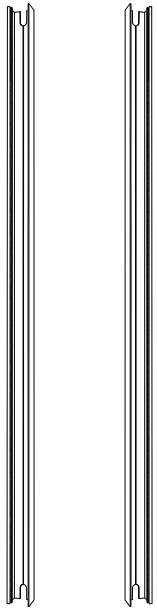

x2

16

Fönsterhöjd/Vinduhøyde/Window height

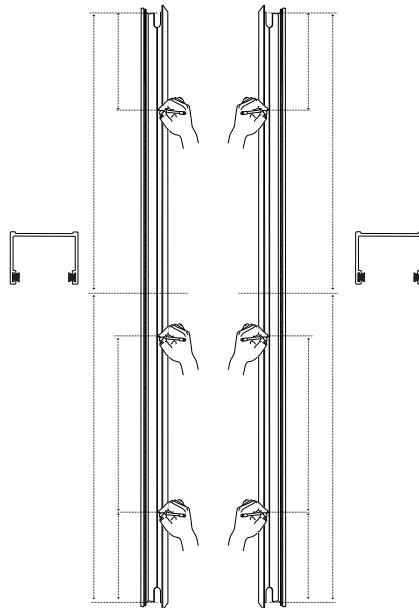

17

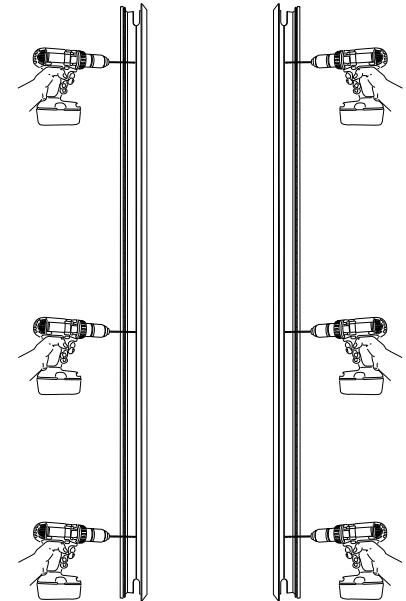

18

*Exempel Rättvänt vänster sida, utifrån - Right-handed left side, from outside.

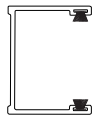
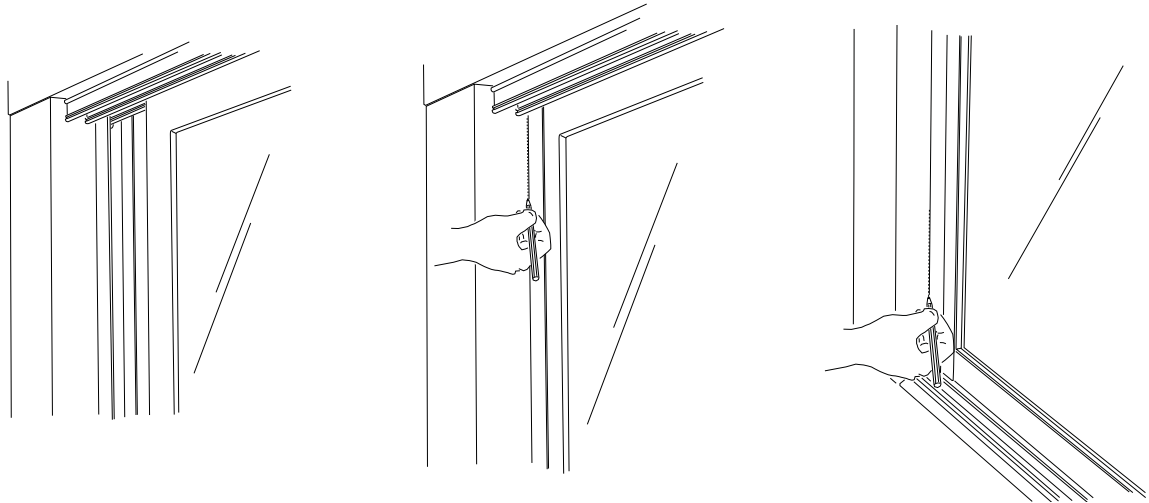

B

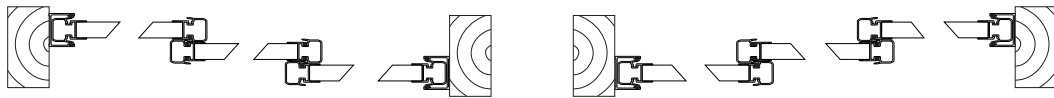

*Rättvänt - Right-handed

Spegelvänt - Left-handed

19

*Exempel Rättvänt höger sida utifrån - Right-handed right side, from outside.

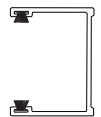
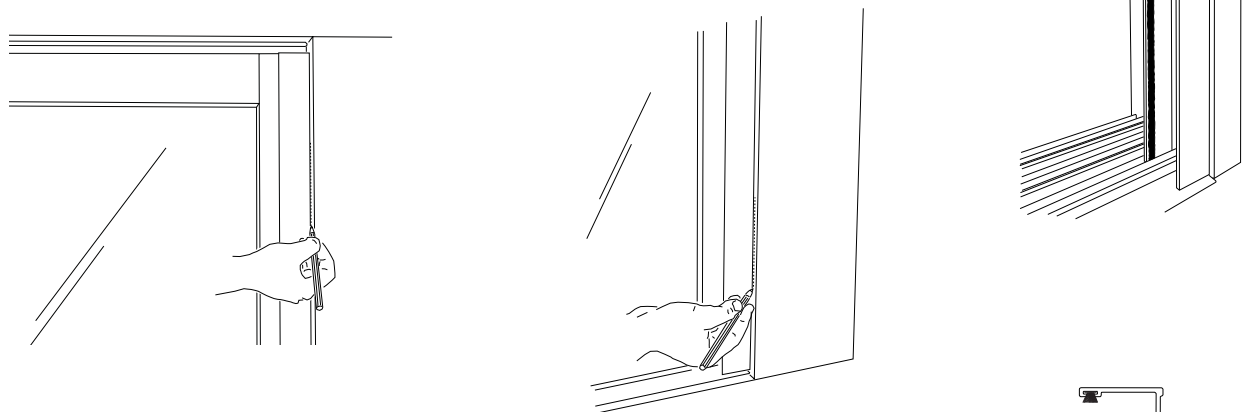

B



*Rättvänt - Right-handed

Spegelvänt - Left-handed

20

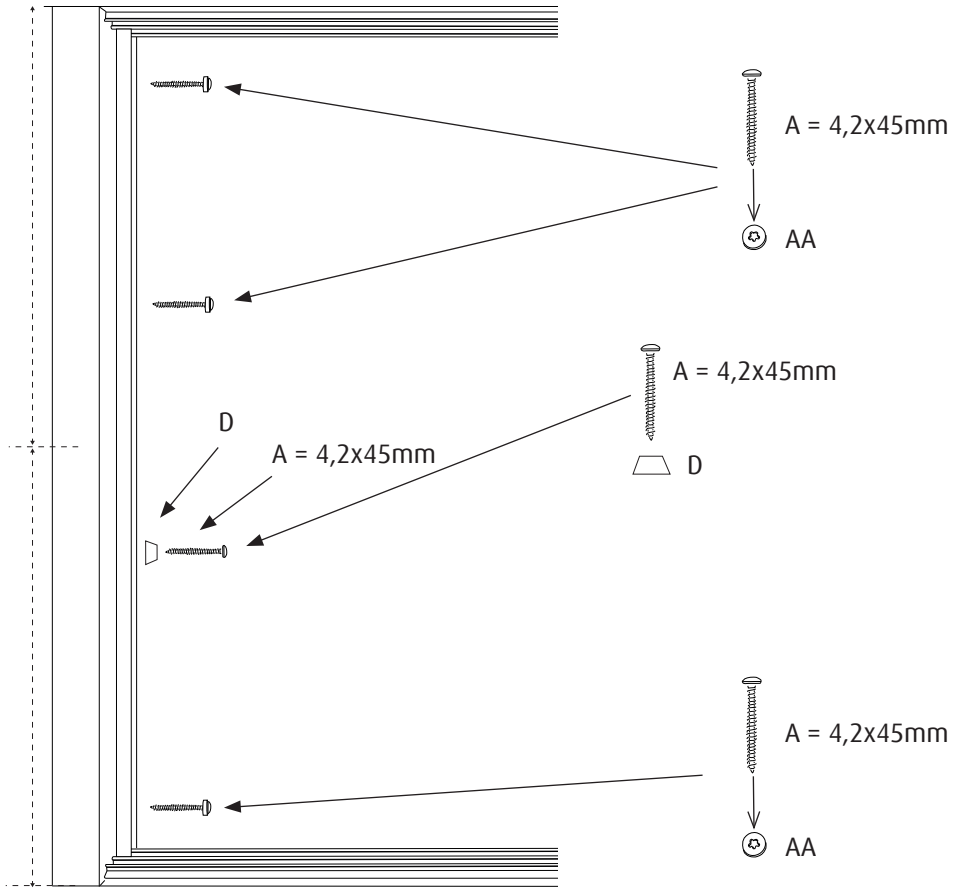

21

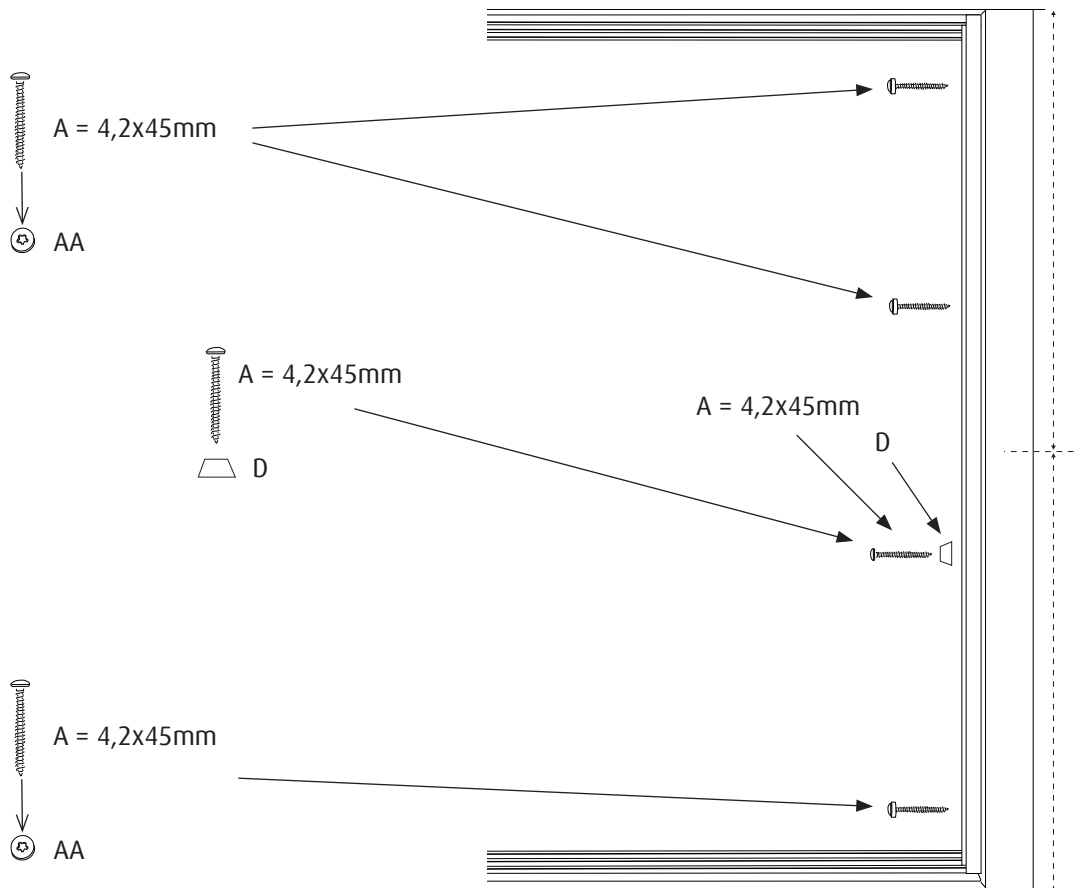

- 22** (SE) Borra EJ igenom hela profilerna. Börja med mindre borrh 3,5 mm. Därefter 7 mm för att ej få ett ovalt hål. *
- (DK) Bor IKKE gennem hele profiler. Start med et mindre bor 3,5 mm. Derefter 7 mm for ikke at få et ovalt hul. *
- (NO) IKKE bor gjennom hele profilene. Start med en mindre drill 3,5 mm. Så 7 mm for ikke å få et ovalt hull. *
- (GB) DO NOT drill through the entire profiles. Start with a smaller diameter drill 3.5 mm. Then 7 mm so as not to get an oval hole. *
- (FI) ÄLÄ poraa profiilien läpi. Aloita pienemmällä 3,5 mm:n poralla. Jatka 7 mm:n poralla, jotta reiästä ei tule soikea. *

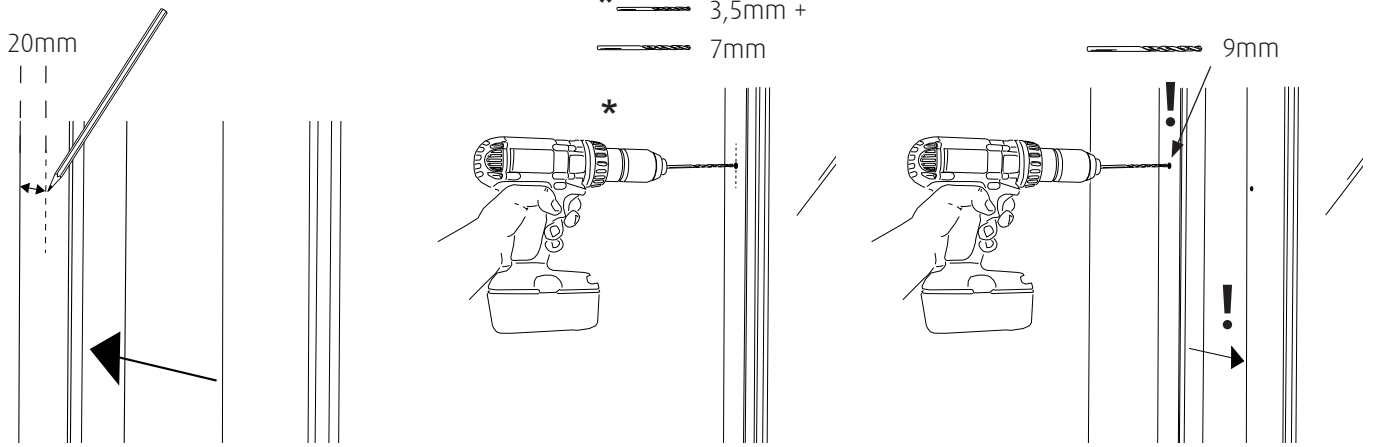
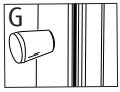

Insida rum / Inde i rummet / Inne i rommet / Inside the room / Huoneen sisällä

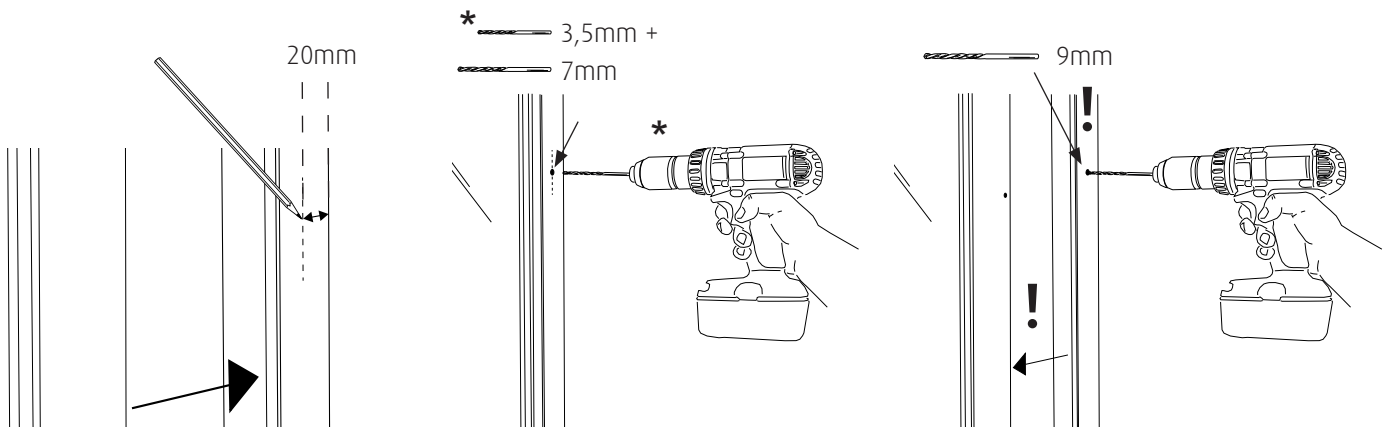

Insida rum / Inde i rummet / Inne i rommet / Inside the room / Huoneen sisällä

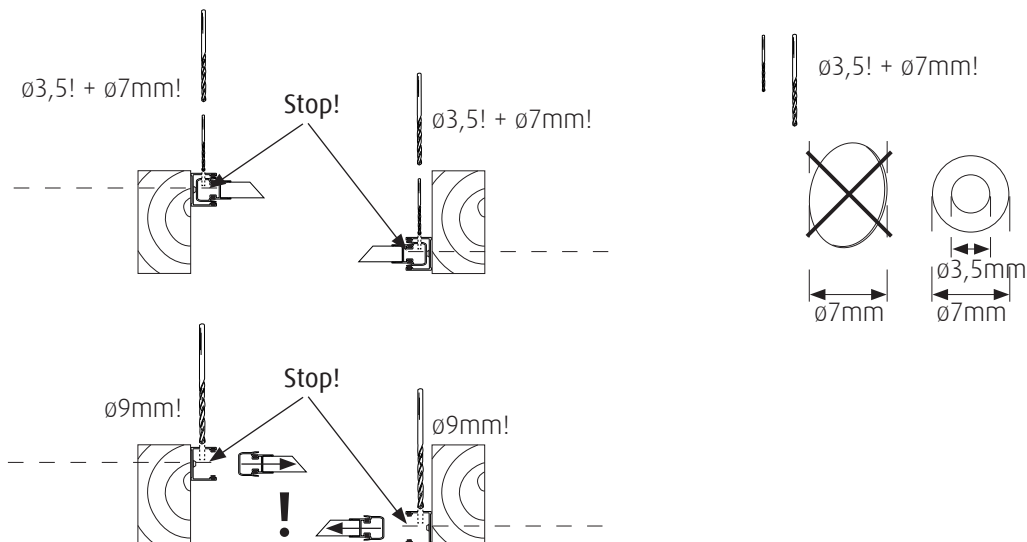

23

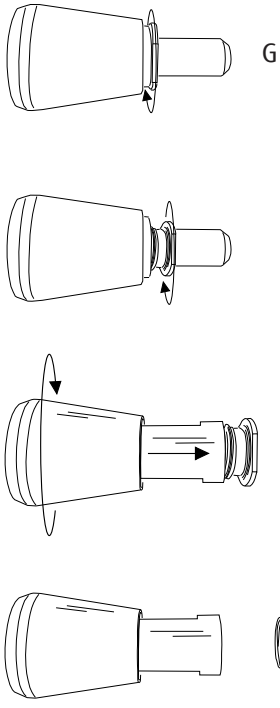

24 G

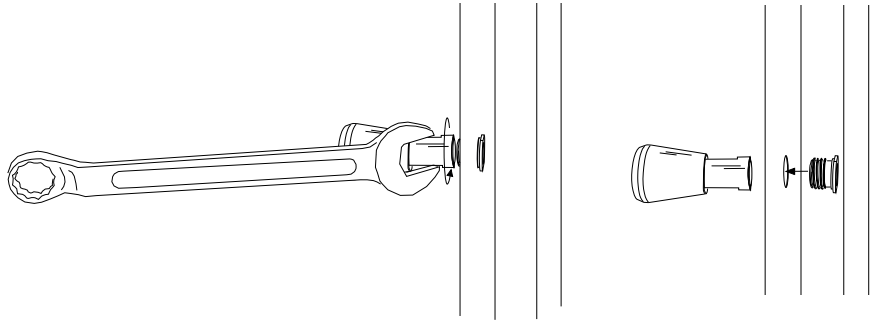

25 G

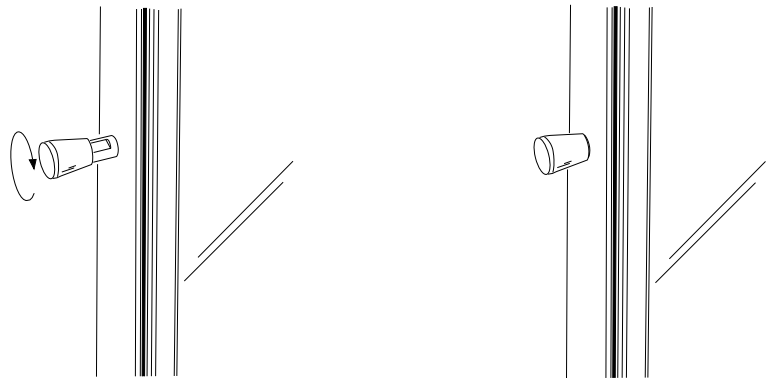

26

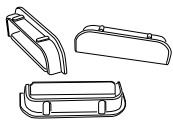

F

Insida rum
 Inde i rummet
 Inne i rommet
 Inside the room
 Huoneen sisällä

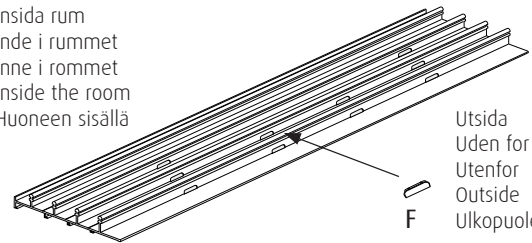

Utsida
 Uden for
 Outside
 Ulkopuolella

Insida rum / Inde i rummet / Inne i rommet / Inside the room / Huoneen sisällä

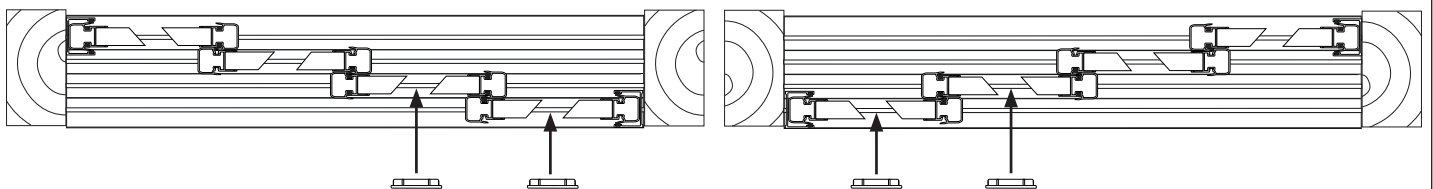
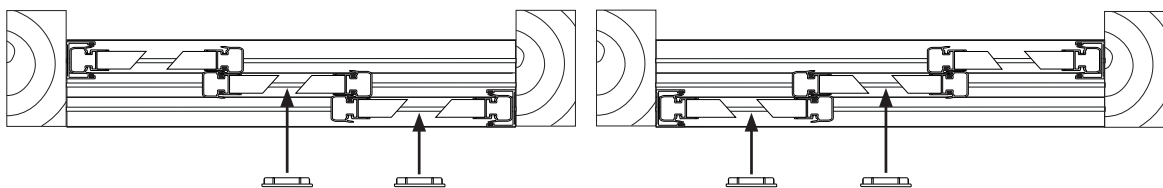
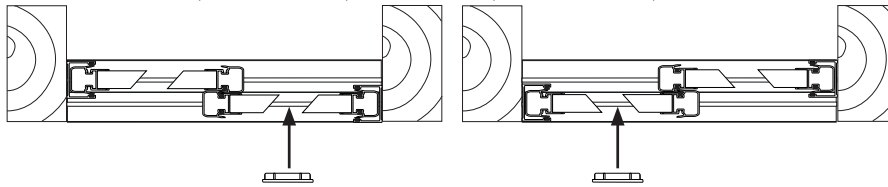

27

- Rengör aluminiumprofilens yta med t.ex T-Röd innan handtaget sätts fast, ytan ska vara torr vid montering.
- Clean the surface of the aluminium profile before attaching the handle, the surface must be dry when mounting.
- Do not clean with anything that damages the paint or gives a greasy surface.

VIKTIGT! Handtaget behöver härda efter montering. Använd ej handtaget direkt. Låt handtaget härda i 24 timmar innan användning!

VIGTIG! Håndtaget skal hærde efter montering. Brug ikke håndtaget med det samme. Lad håndtaget hærde i 24 timer inden brug!

VIKTIG! Håndtaket må herdes etter montering. Ikke bruk håndtaket direkte. La håndtaket stivne i 24 timer før bruk!

IMPORTANT! The handle needs to harden after mounting. Do not use the handle immediately. Let the handle harden for 24 hours before use!

TÄRKEÄÄ! Kahvan on annettava kovettua asennuksen jälkeen. Älä käytä kahvaa heti. Kovettuminen kestää 24 tuntia!

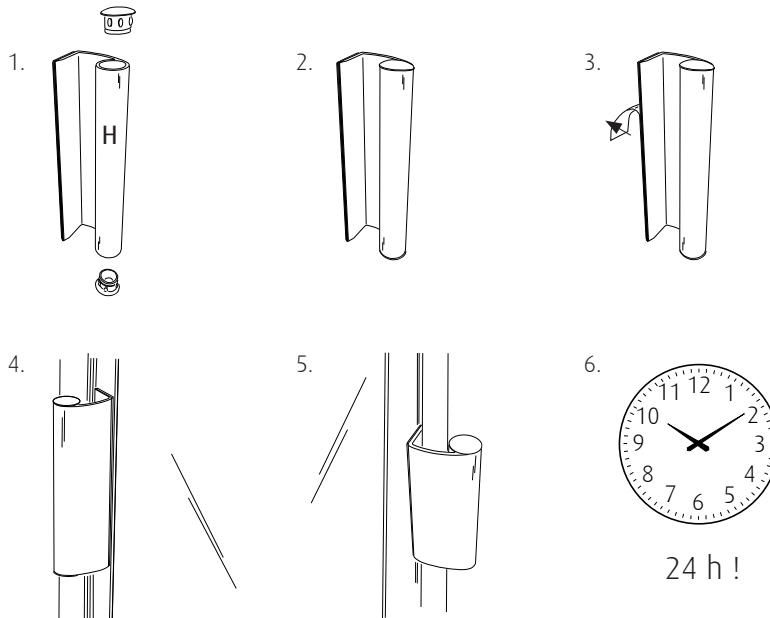

28

Kontrollera alltid funktion och montering efter utfört arbete även om det utförts av utomstående installatör, innan de lämnar platsen. På det viset får ni en genomgång av produkten och dess funktion och skötsel.

Always check the function and installation after work has been carried out, even if it has been carried out by a third-party installer, before leaving the site. In this way, you get an overview of the product and its function and care.

Var akksam och se till så att partierna står stabilt placerat under tiden för monteringen, ett fallande parti kan orsaka skada på produkten eller orsaka skada på person och omgivning.

Be careful and make sure that the parts are stably placed during the assembly, a falling part can cause damage to the product or cause personal injury and damage to the surroundings.

Kontroll av funktion och skötsel.

Följande bör kontrolleras med regelbundenhet:

- Funktionen på dörrarna.
- Funktion på eventuella Lås.
- Gångjärn och hjul ska löpa lätt.
- Handtag vid öppning och stängning.
- Lister ska vara hela och rena.

Checking the function and maintenance.

The following should be checked regularly:

- The function of the doors.
- Function of any locks
- Hinges and wheels should operate smoothly.
- Handle when opening and closing.
- Mouldings must be intact and clean.

Viktigt om glas!

Stora ojämnheter i temperatur på delar av glaset kan skapa termisk spänning. Placera ej värmeelement mot glas eller värmefläkt som riktas direkt mot glaset då termiska spänningar i glaset kan uppstå och föranleda sprickbildning. Placera ej möbler, kuddar, dynor eller liknande mot glaset. Montera ej klistermärken som ej är avsedda för glas eller skyltar på glaset.

Important information about glass!

Large variations in temperature on parts of the glass can create thermal stress. Do not place heating elements against glass or heating fans that are directed directly at the glass as thermal stresses in the glass can occur and cause cracks to form. Do not place furniture, pillows, cushions or the like against the glass.

Do not apply stickers that are not intended for glass or signs on the glass.

HALLE

Halle
Profilgatan 1
312 34 Laholm
www.halle.se